

NOTE: THE VERTICAL STRETCH RATIO FOR THIS BOTTLE IS 1.74 : 1

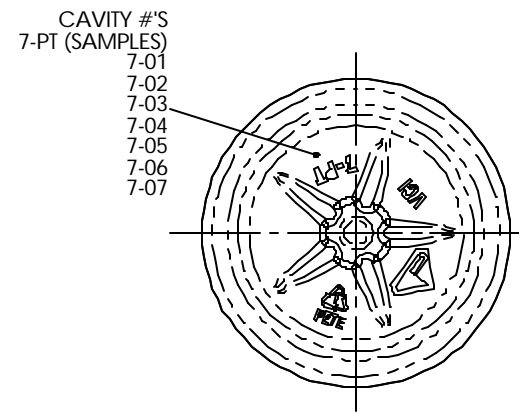

AS PER SAMPLES SUPPLIED UNDER HALLINK JOB # H02692

PART DRAWING TO BE APPROVED PRIOR TO MOULD PRODUCTION
 APPROVED BY: _____
 DATE: _____

BOTTLE OVERFLOW CAPACITY	PART WEIGHT	
379 ml ±9ml	19.8 g	
	APPROVALS	DATE
MATERIAL PETE	DRAWN JB	08/26/02
NECK FINISH	CHECKED JMV	08/26/02
28 mm PCO	ISSUED JB	08/26/02
DO NOT SCALE DRAWING		



12 oz US Water Bottle	
JOB NO.	H02731
CUSTOMER NO.	H1346
This drawing subject to standard industry tolerances. (S.P.I.)	
SCALE 1:1	SHEET OF